

Stepper Motor M565

SPECIFICATIONS

PHASE	STEP ANGLE	CONNECTION STYLE	CURRENT	RESISTANCE	INDUCTANCE	HOLDING TORQUE	CLASS OF INSULATION	WEIGHT
	DEG/STEP		A	ohms±10%	mH±20%	N.m		Kg
2	1.8	parallel	4.0	0.7	3.0	4.0	B	1.4
2		series	2.0	2.8	12.0	4.0		
4		unipolar	2.8	1.4	3.0	2.8		

DIMENSION: Units :mm

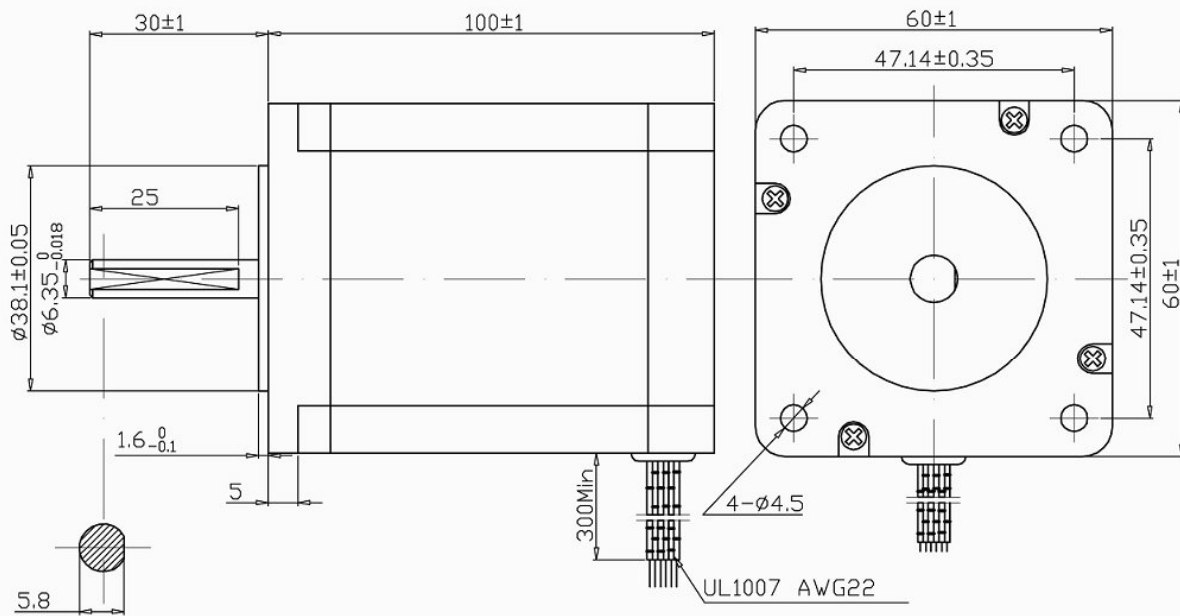

WIRING DIAGRAM

