

# TL100 Lifter



- 1- DC Motor & Gearbox
- 2- Lead screw drive nut
- 3- Round linear guide
- 4- Standard torch holder
- 5- 3 limit switches, 2 for Limit and 1 for touch control
- 6- Switch connector (see wiring below)

# TL100 Lifter

Dimension in mm

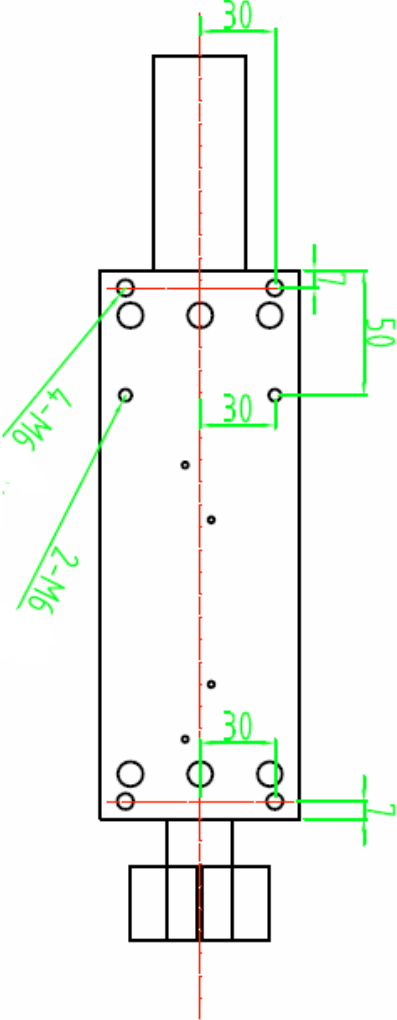
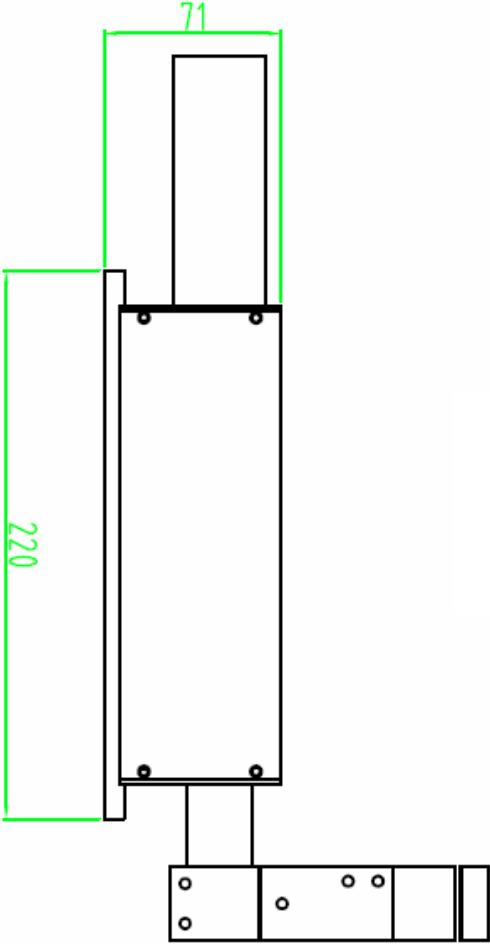
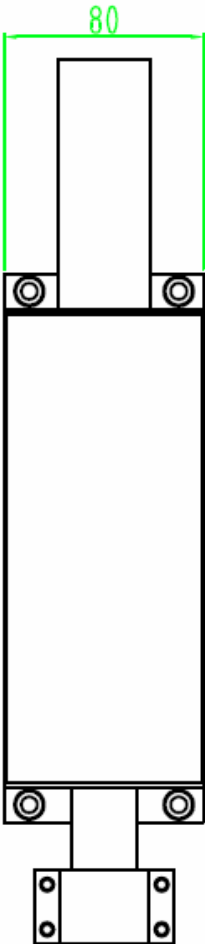
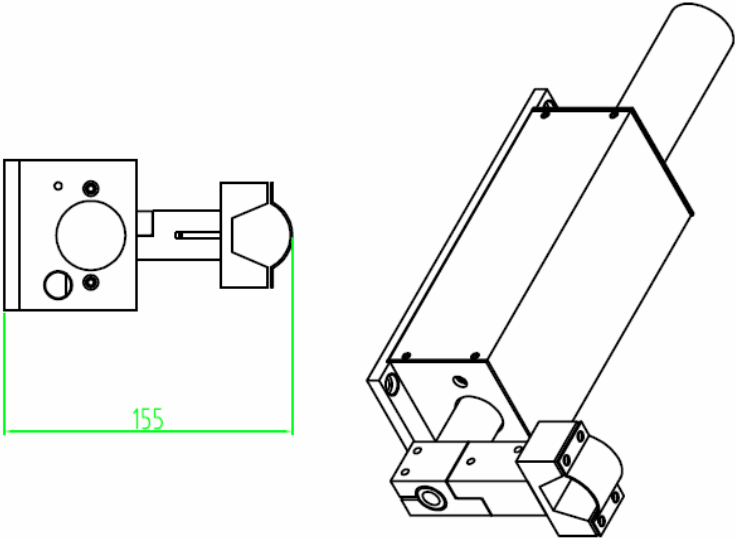

# TL100 LIFTER WIRING INTRO

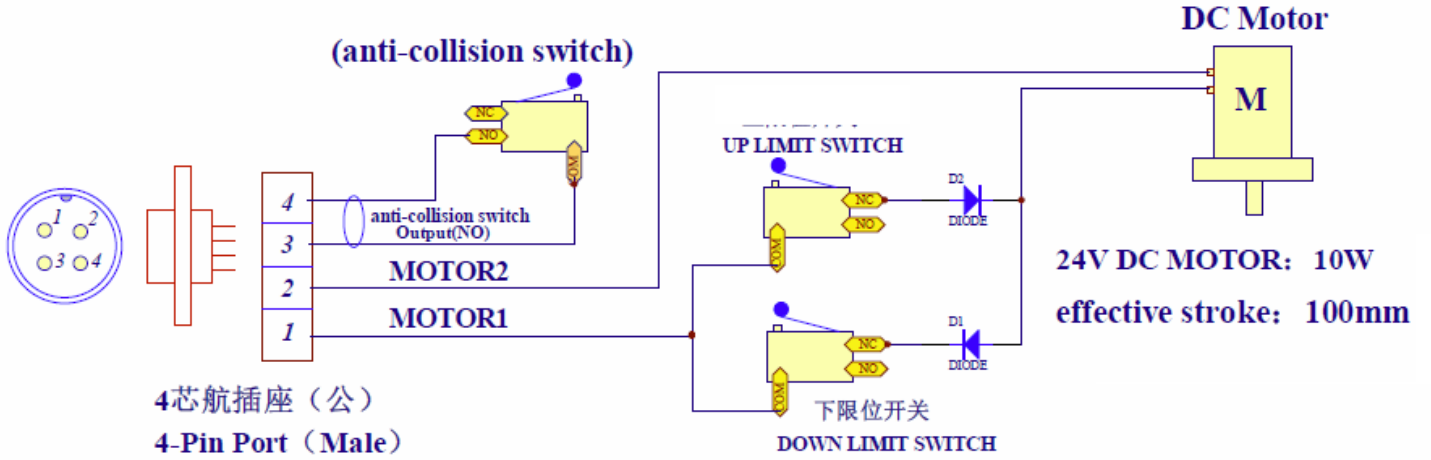

4芯航插座（公）  
4-Pin Port（Male）

PIN1 & PIN2	PIN3&PIN4
DC MOTOR	anti-collision switch Output(NO)

NOTE: 1.Limit switch is normally closed.